

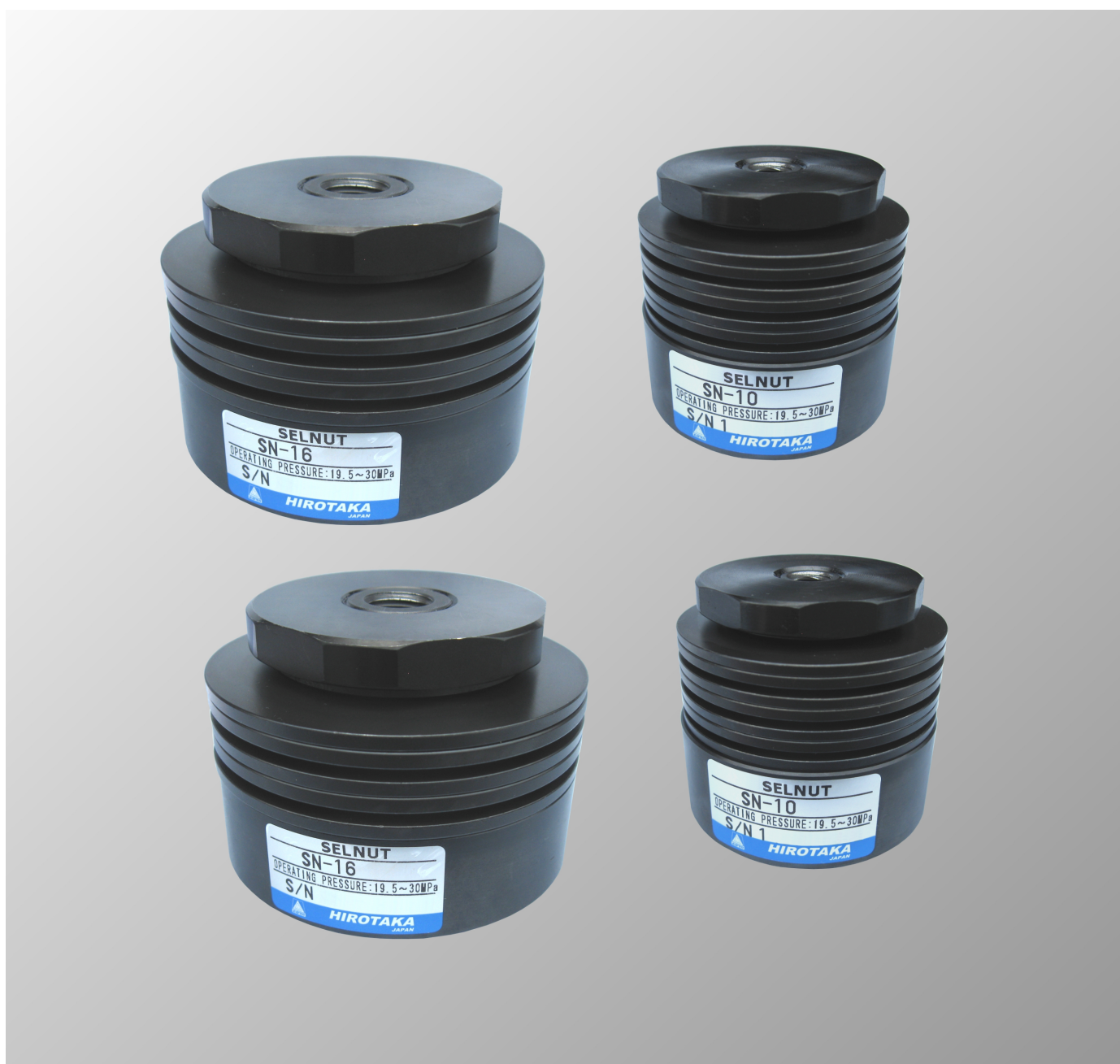

Single action spring clamp

SELNUT



HIROTA MFG. CO.,LTD.

SELNUT

Compact and lightweight powerful spring type tightening nut.

Use this clamp for automation and labor saving of JIG.

Overview

The SELNUT is a product that automates the tightening nut for bolt-type clamps. It is an automatic clamping device that eliminates variations in clamping force, shortens clamping time, and saves labor in clamping to improve work safety and efficiency.

Specifications

Model	SN-10	SN-12	SN-16
Maximum clamping force	7.3 kN	13 kN	13 kN
Stroke	3 mm		
Screw hole diameter	M10P1.5	M12P1.5	M16P1.5
Amount of oil	1.36 cm ³	2.8 cm ³	2.8 cm ³
Operating pressure	19.5 to 30 MPa		
Mass	1.1 kg	2.3 kg	2.3 kg

Feature

- 1 Compact and lightweight with strong clamping force.
- 2 Mounting screws size are M 10 to M 16, clamping force is 7.3 to 13 kN.
- 3 There is no looseness even if troubles such as vibration, piping, etc. occur during clamping, or power outages occur.
- 4 There is no misalignment of the workpiece when tightening, and uniform tightening force can be easily obtained.

How to order

SN - 10

Series	Symbol	Model
SELNUT	10	SN-10
	12	SN-12
	16	SN-16

Action description

Clamp when oil pressure is released.

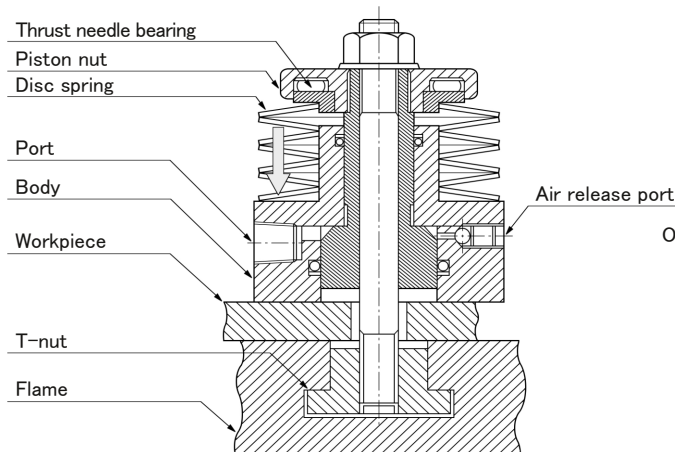

Unclamp when oil pressure is supplied.

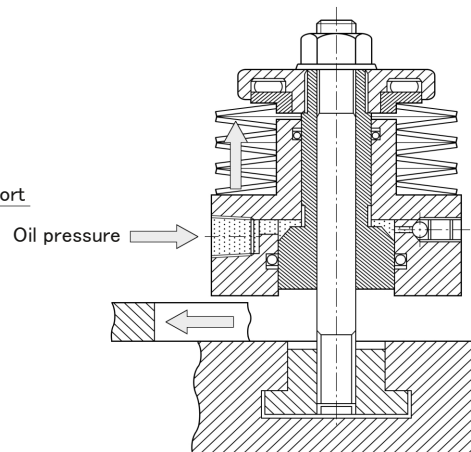

Unclamped by supplying oil pressure to the hydraulic port and compressing the disk spring.

How to use

Supply oil pressure to the SELNUT port to unclamp.

As shown in the right figure, after inserting the slotted hole of the workpiece into the SELNUT set on the T-nut, release the oil pressure and clamp it.

Very smooth, safety and reliable work can be done.

Use the RUSH BOOSTER that can convert from pneumatic to the oil pressure source.

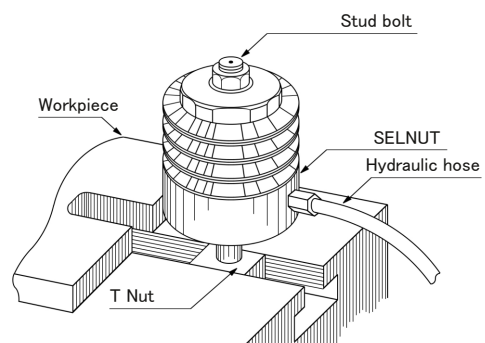

Dimensions

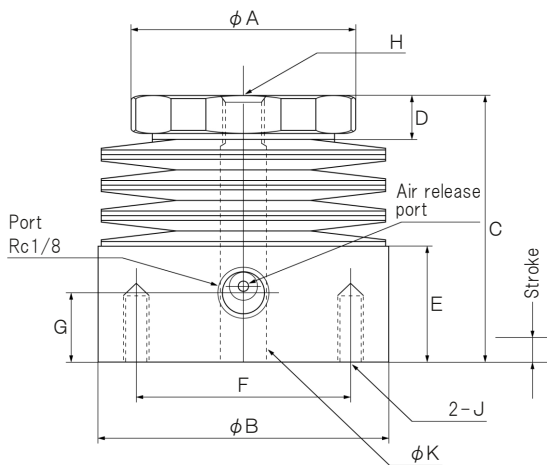

Unit: mm

Model Symbol	SN-10	SN-12	SN-16
A	52	70	70
B	64	89	89
C	59	63	63
D	7	10	10
E	26	26	26
F	48	70	70
G	15	15	15
H	M10×1.5 Depth 20	M12×1.75 Depth 20	M16×2.0 Depth 20
J	M6×1.0 Depth 15	M6×1.0 Depth 15	M6×1.0 Depth 15
K	10.5	16.5	16.5

Stroke and clamping force

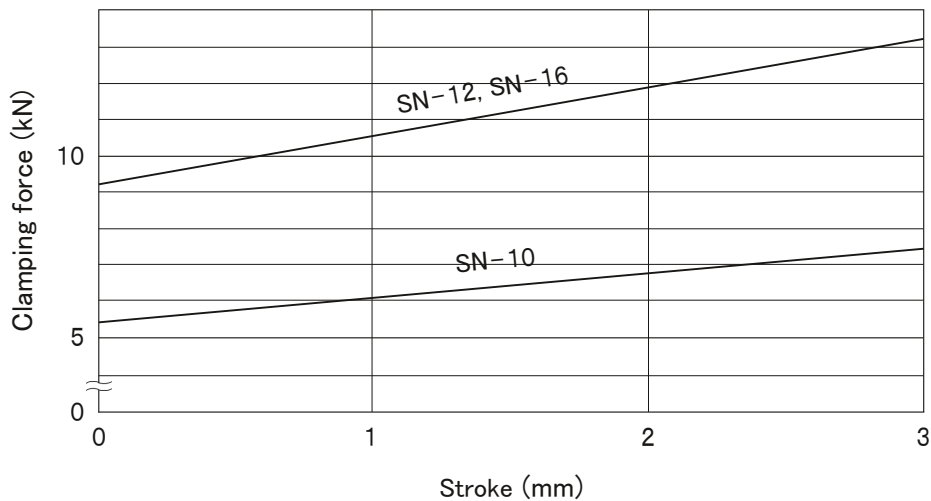

Suitable for oil pressure source for unclamping SELNUT.

Air-hydro booster

RUSH BOOSTER

Overview

The rush booster is an air-hydro booster that can generate oil pressure with compressed air.

It can be operated with one pneumatic valve and converted to high oil pressure equivalent to 5 to 100 times the air pressure.

Use as a hydraulic source for short stroke hydraulic cylinders, automatic clamp devices, etc.

Feature

- ① Converts 0.4 MPa air pressure to 25 MPa oil pressure.
- ② Since it operates with an air pressure, there is no trouble due to oil temperature rise even in the state of continuous operation and pressure holding.
- ③ The oil pressure can be changed steplessly by changing the air pressure.
- ④ Control can be done with an one pneumatic valve.

How to order

RB 160 × 30 - 65

Boosting ratio: 64 times

Amount of discharge oil: 30 cm³

50 cm³

80 cm³

100 cm³

130 cm³

160 cm³

Bore size: 160 mm

Product name: RUSH BOOSTER

Specifications

Model No.	RB 160 × Amount of discharged oil - 65
Bore size	160 mm
Ram diameter	20 mm
Pressure increase ratio	64 times
Amount of discharged oil	30 cm ³ , 50 cm ³ , 80 cm ³ , 100 cm ³ 130 cm ³ , 160 cm ³ , 200 cm ³ , 250 cm ³
Maximum generated oil pressure	45.5 MPa (At air pressure 0.7 MPa)
Operating pressure	0.3 to 0.7 MPa
Fluid (Air pressure)	Air
Fluid (Oil pressure)	Standard mineral hydraulic fluid

Piping

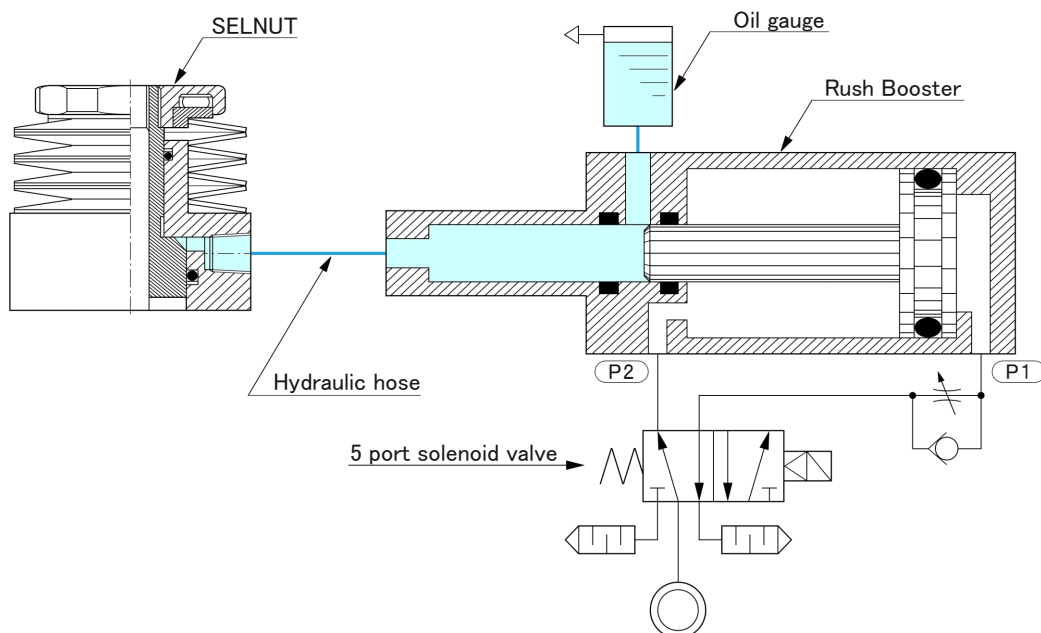

When compressed air is supplied to P1 of the Rush Booster, the piston moves forward and the oil becomes high pressure according to Pascal's principle, and the SELNUT will be in an unclamped state.

When compressed air is supplied to P2, the SELNUT will clamp by the force of the disk spring.

It is recommended to install the Rush Booster at a position higher than the SELNUT in consideration of air release.

Dimensions

RB 160 × Amount of discharged oil – 65

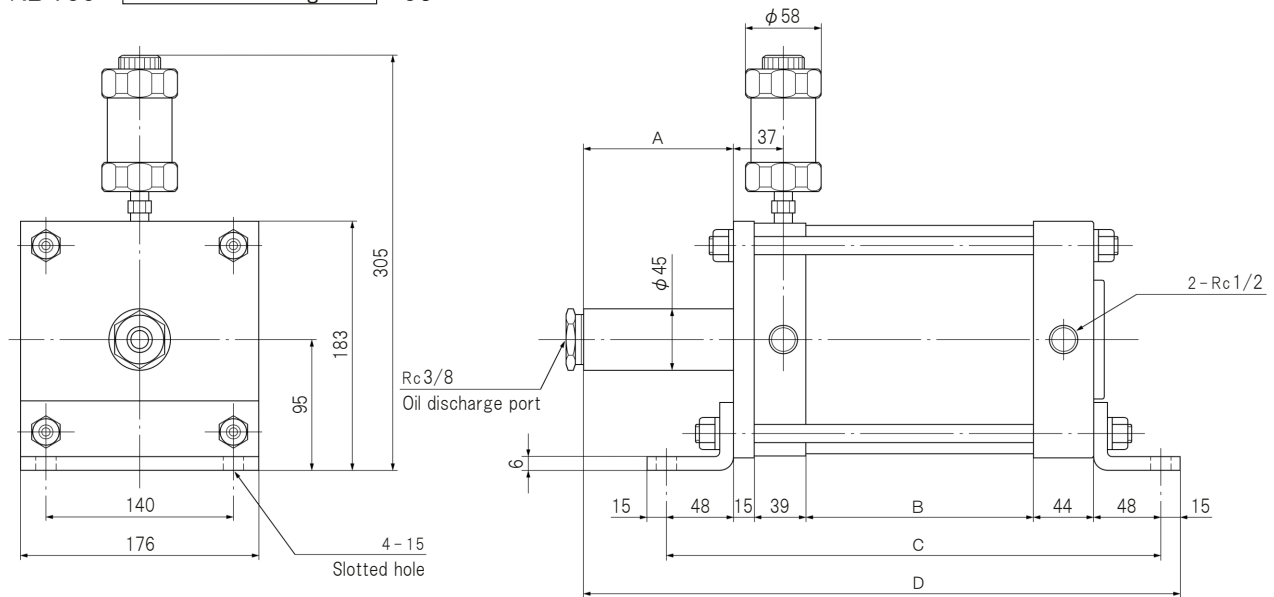

Amount of discharged oil	30 cm ³	50 cm ³	80 cm ³	100 cm ³	130 cm ³	160 cm ³
Symbol						
A	135	195	295	355	450	545
B	176	236	336	396	491	586
C	370	430	530	590	685	780
D	472	592	792	912	1102	1292

Precautions for hydraulic piping

Rush Booster is above the SELNUT.

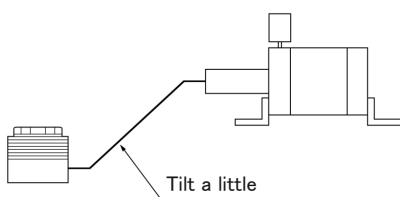

Rush Booster is below the SELNUT.

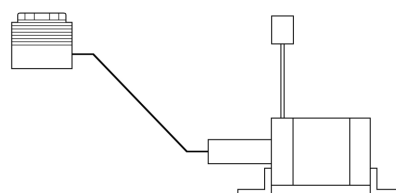

Use the low oil pressure piping and install the oil gauge at a position higher than the SELNUT.

The hydraulic piping becomes like a mountain.

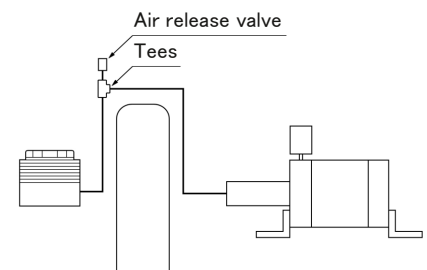

Install the air release valve at the highest point of the hydraulic piping.



●LINE UP●

PNEUMATIC POWER CYLINDER

PNEUMATIC BOOSTER

POWER PACK CYLINDER

RUSH BOOSTER

HYDRAULIC CYLINDER

FREE LOCK PAD

SELLOCK CYLINDER

FLOATING CONNECTOR

AUTO CLAMPER

SEL NUT

LINEA BRAKE

PNEUMATIC AND HYDRAULIC

EQUIPMENT