

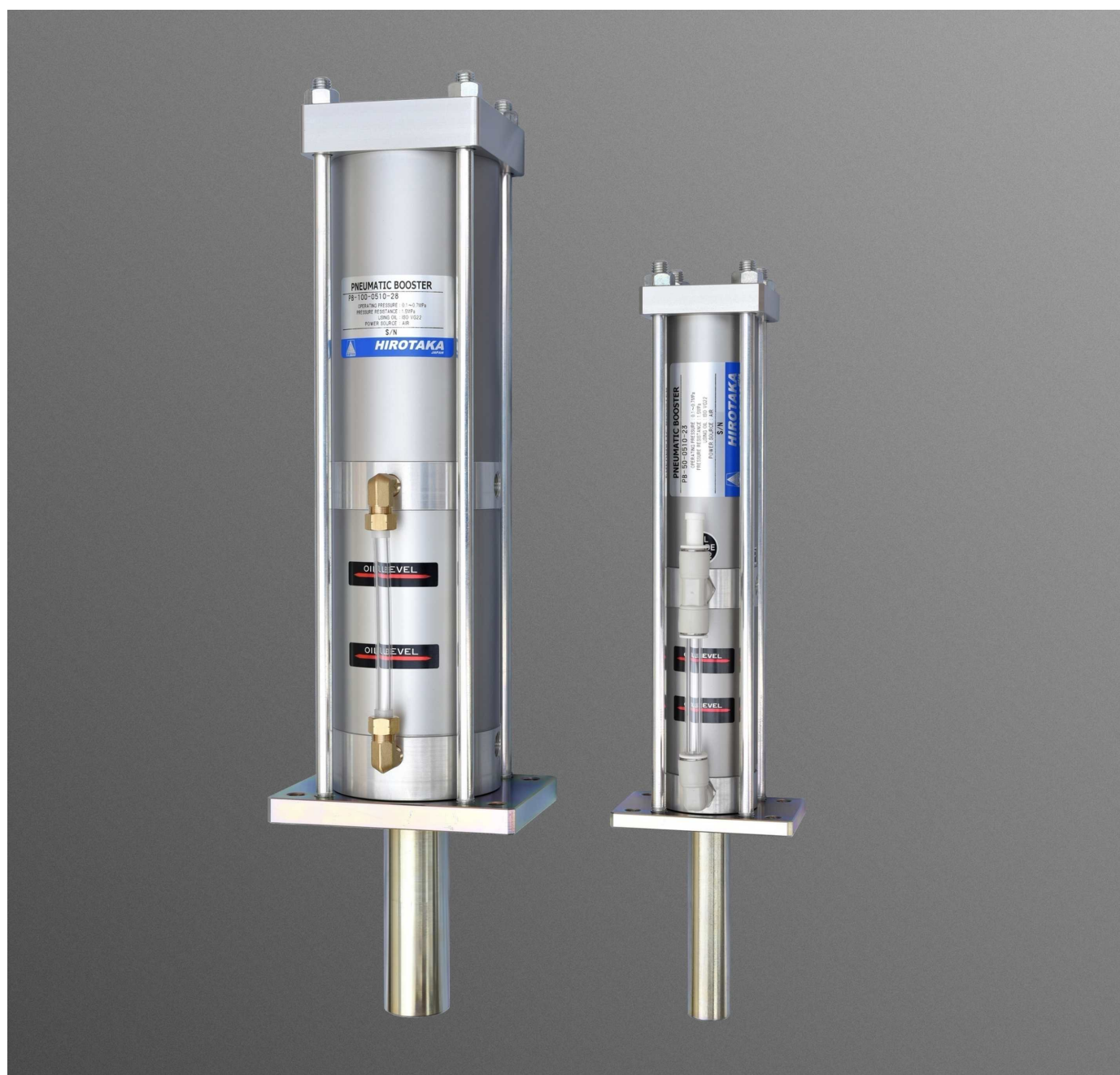

Air-Hydro Booster with Converter

PNEUMATIC BOOSTER

It is a product with a wide range of applications that can be converted to large capacity, high pressure only with air pressure.



HIROTAKA MFG. CO.,LTD.

Air-Hydro Booster with Converter

PNEUMATIC BOOSTER

Generates high capacity of low pressure, high pressure hydraulic pressure using only compressed air.

Simple mechanism that does not require a hydraulic pump, etc.

Overview

The pneumatic booster is a two stage hydraulic power unit that efficiently generates high volume, high pressure hydraulic flow using compressed air.

Eliminates the need for hydraulic pumps and solenoid valves, allowing you to operate hydraulic cylinders and equipment using only pneumatic valves.

Feature

- 1 Using only compressed air, it provides both high pressure hydraulic power (up to 21 MPa) and high volume, low pressure hydraulic flow.
- 2 Two stage discharge can be easily controlled using a pneumatic valve.
- 3 It consumes less air than a pneumatic cylinder while generating the same amount of thrust.
- 4 The unique internal structure eliminates air ingestion and the need for air bleeding, ensuring continuous and stable operation.
- 5 The simple design ensures trouble free operation.
- 6 Since there is no rise in oil temperature, consistent and stable operation is maintained.
- 7 The hydraulic pressure can be adjusted steplessly by changing the input air pressure.

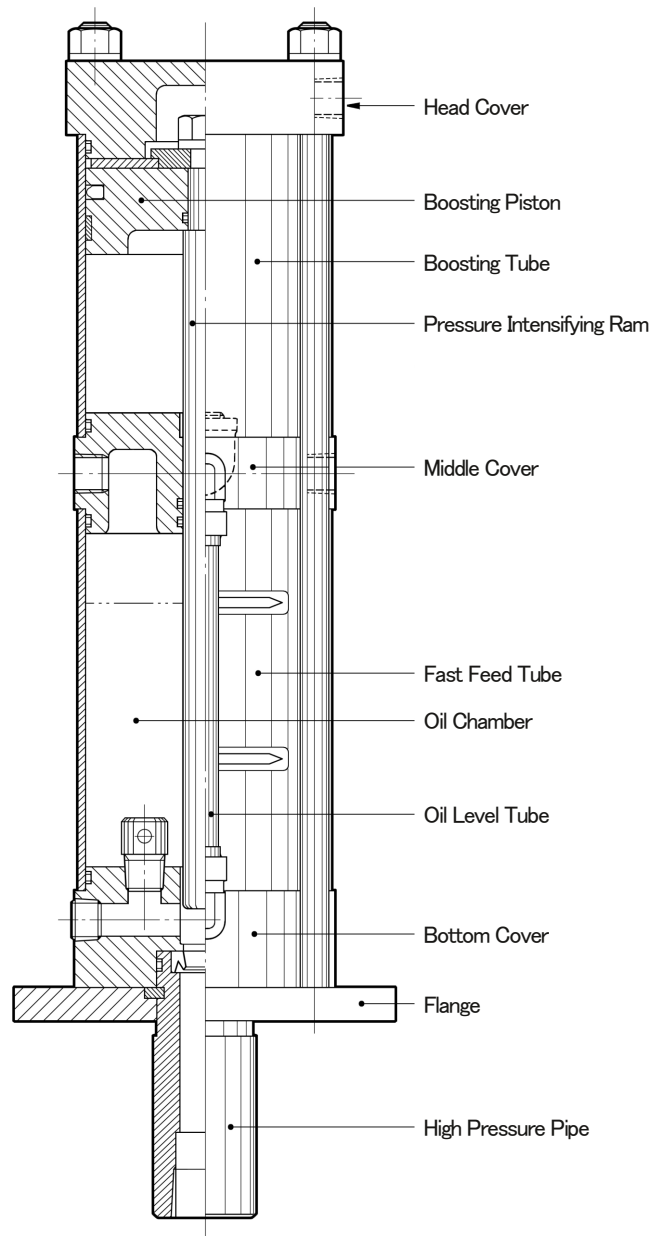

Structure and Operating Principle

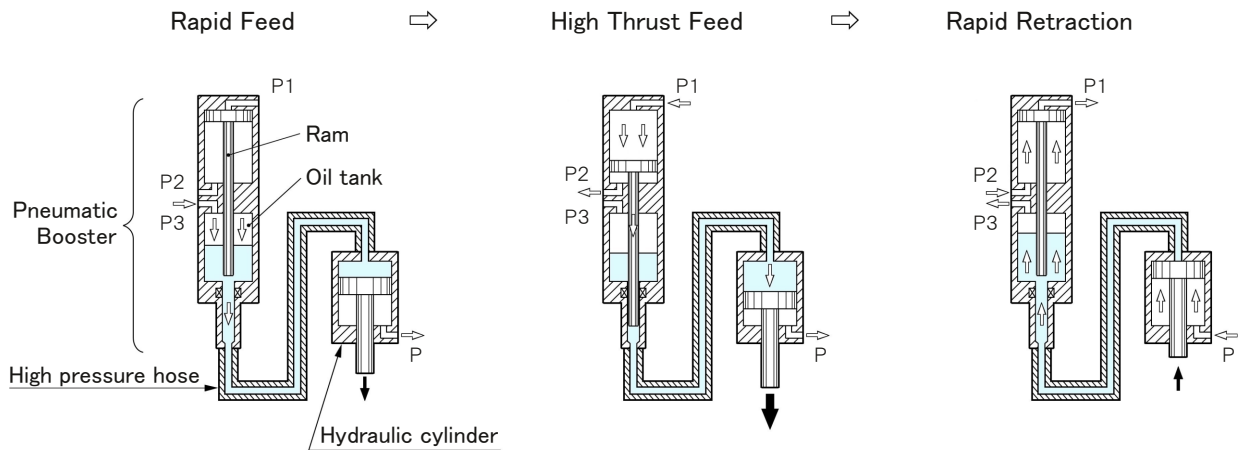

Supplying air to the P3 port causes the oil in the tank to drive the hydraulic cylinder forward at high speed. Although the pressure is equivalent to the air pressure, the large volume of oil flowing into the cylinder enables high speed forward movement.

When air is supplied to the P1 port, the ram advances while sealing in the oil, generating high pressure within the hydraulic cylinder. As a result, the hydraulic cylinder advances with high thrust.

Supplying air to the P and P2 ports retracts the ram, causing the hydraulic cylinder to perform a rapid retraction.

Basic Pneumatic Circuit

Standard pneumatic circuit

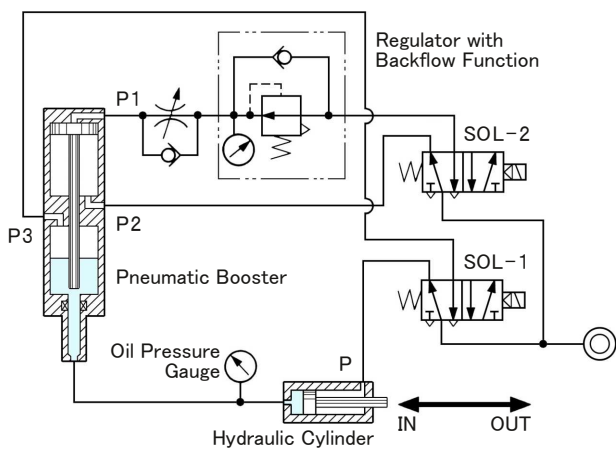

Operating condition	SOL-1	SOL-2
Rapid feed	ON	OFF
High thrust feed	ON	ON
Rapid retraction	OFF	OFF

- ① Install meter-out speed controllers on the P and P3 ports to control rapid feed and rapid retraction speeds.
- ② If air bubbles occur within the oil level gauge, install meter-out speed controller at the P1 port.
- ③ Install regulator when adjusting the high thrust to a lower level. (To prevent any loss of thrust during rapid feed and retraction)

High thrust from start-up

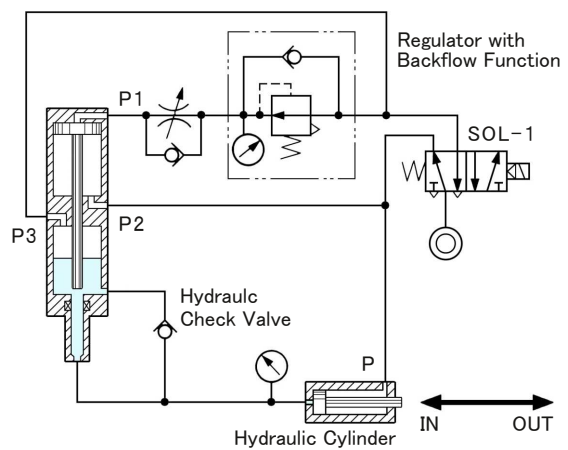

This circuit for applications requiring high starting thrust to dislodge stuck parts, followed by rapid feed movement.

Operating condition	SOL-1
High thrust feed	ON
Rapid feed	ON
Rapid retraction	OFF

- ① Speed adjustment is the same as the standard pneumatic circuit. Note : As this model is built to custom specifications, inquire with us when considering it for your application.
- ② Recommended cracking pressure for the hydraulic check valve 0.05 MPa or lower.

Specifications

Model	(Theoretical value)						
	PB-50- □-23	PB-100- □-16	PB-100- □-28	PB-160- □-16	PB-160- □-28	PB-200- □-25	PB-300- □-29
Pneumatic cylinder diameter	φ 50	φ 100	φ 100	φ 160	φ 160	φ 200	φ 300
Booster ram diameter	φ 10	φ 25	φ 18	φ 40	φ 30	φ 40	φ 55
Pressure boosting ratio	1 : 25	1 : 16	1 : 30	1 : 16	1 : 28	1 : 25	1 : 29
Maximum generated oil pressure (with 0.7 MPa air pressure)	17 MPa	11 MPa	21 MPa	11 MPa	19 MPa	17 MPa	20 MPa
Rapid feed discharge flow rate (with 0.7 MPa air pressure)	20L/min	63L/min	63L/min	295L/min	295L/min	452L/min	452L/min
High thrust feed discharge flow rate (with 0.7 MPa air pressure)	2.3L/min	14.7L/min	7.6L/min	31.8L/min	17.3L/min	37.3L/min	50L/min
Pneumatic port size	Rc 1/4	Rc 3/8	Rc 3/8	Rc 1/2	Rc 1/2	Rc 3/4	Rc 1
Oil discharge port size	Rc 1/2	Rc 3/4	Rc 3/4	Rc 1 1/4	Rc 1 1/4	Rc 1 1/2	Rc 1 1/2
Fluid	Air						
Hydraulic fluid	Standard mineral hydraulic fluid (ISO : VG22)						
Proof pressure (Air)	1.5 MPa						
Operating pressure (Air)	0.1~0.7 MPa						
Ambient temperatures	5~40°C						
Mounting type	Flange type						

Discharge flow rate and maximum hydraulic pressure are values for the pneumatic booster unit under no-load conditions.
(Values may vary depending on conditions such as the minimum operating pressure of the hydraulic cylinder, load magnitude, pressure drop, piping diameter and length, and other environmental factors.)

Thrust Table for Hydraulic Cylinder at High Thrust Feed

Operating air pressure (MPa)		Unit : kN (Theoretical value)									
		0.3		0.4		0.5		0.6		0.7	
Bore size (mm)	Piston area (mm ²)	Pressure boosting ratio		Oil pressure (MPa)		1 : 16		1 : 28		1 : 28	
		1 : 16	1 : 28	1 : 16	1 : 28	1 : 16	1 : 28	1 : 16	1 : 28	1 : 16	1 : 28
		4.8	8.4	6.4	11.2	8.0	14.0	9.6	16.8	11.2	19.6
32	804	3.8	6.7	5.1	9.0	6.4	11.2	7.7	13.5	9.0	15.7
40	1257	6.0	10.5	8.0	14.0	10.0	17.5	12.0	21.1	14.0	24.6
50	1963	9.4	16.5	12.5	21.9	15.7	27.4	18.8	32.9	21.9	38.4
63	3117	14.9	26.1	19.9	34.8	24.9	43.6	29.9	52.3	34.8	61.0
80	5027	24.1	42.2	32.1	56.2	40.1	70.3	48.2	84.4	56.2	98.5
100	7854	37.6	65.9	50.2	87.9	62.8	109.9	75.3	131.9	87.9	153.9
125	12272	58.8	103.0	78.5	137.4	98.1	171.7	117.7	206.1	137.4	240.5
160	20106	96.4	168.8	128.6	225.1	160.8	281.4	192.9	337.6	225.1	393.9
180	25447	122.1	213.7	162.8	285.0	203.5	356.2	244.2	427.4	284.9	498.6
200	31416	150.7	263.8	201.0	351.8	251.2	439.8	301.5	527.7	351.7	615.7
250	49087	235.5	412.3	314.1	549.7	392.6	687.1	471.1	824.6	549.6	962.0

To calculate the high thrust of PB-50, multiply the value at a 1:28 pressure boosting ratio by 0.89.
To calculate the high thrust of PB-100 1:28, multiply the value at a 1:28 pressure boosting ratio by 1.08.
To calculate the high thrust of PB-200, multiply the value at a 1:28 pressure boosting ratio by 0.89.
To calculate the high thrust of PB-300, multiply the value at a 1:28 pressure boosting ratio by 1.03.

Flow Rate Characteristics

Rapid feed discharge flow rate Unit : L/min			High thrust feed discharge flow rate Unit : L/min				
Load factor (%)	PB-100	PB-160	Load factor (%)	PB-100-□-16	PB-100-□-28	PB-160-□-16	PB-160-□-28
30	53	247	30	14.2	7.1	29.8	16.3
50	45	209	50	13.6	6.8	28.5	15.5
70	34	161	70	12.4	6.2	26.1	14.2

※ This indicates the load ratio of the Pneumatic Booster when the operating air pressure is 0.7 MPa.
(Values may vary depending on conditions such as the minimum operating pressure of the hydraulic cylinder, load magnitude, pressure drop, piping diameter and length, and other environmental factors.)
Contact us for the discharge flow rate of PB-50, 200 and 300.

How to Order

PB - 100 - 10 15 - 28



Example	
PB-100-1015-28	
Bore Size	: 100 mm
Rapid Feed Oil Capacity	: 280 cm ³
High Thrust Feed Oil Capacity	: 30 cm ³
Pressure Boosting Ratio	: 1 : 28

① Bore Size	
Symbol	Bore size
50	50 mm
100	100 mm
160	160 mm
200	200 mm
300	300 mm

② Rapid Feed Oil Capacity						Unit: cm ³
Model	PB-50-□	PB-100-□	PB-160-□	PB-200-□	PB-300-□	
Symbol	-23	-16 (28)	-16 (28)	-25	-29	
05	30	80	100	1500	3500	
10	80	280	600	3100	7000	
15	130	480	1100	4700	10600	
20	180	680	1600	6200	14100	
25	230	880	2100	7800	17600	

④ Pressure Boosting Ratio	
Bore size	Boosting Ratio
50 mm	1 : 23
100 mm	1 : 16
	1 : 28
160 mm	1 : 16
	1 : 28
200 mm	1 : 25
300 mm	1 : 29

③ High Thrust Feed Oil Capacity								Unit: cm ³
Model	PB-50-□	PB-100-□	PB-100-□	PB-160-□	PB-160-□	PB-200-□	PB-300-□	
Symbol	-23	-16	-28	-16	-28	-25	-29	
05	2.5	22	10	60	30	60	110	
10	6.5	44	20	120	60	120	230	
15	10.5	66	30	180	90	180	350	
20	14.0	88	40	240	120	240	470	
25	17.5	110	50	310	150	310	590	

Actual pressure ratio
 PB-100-□-28 1:30
 PB-50-□-23 1:25

Model Selection Guide

- Determine the total stroke of the hydraulic cylinder required for the operation.
 (Example : If a 70 mm clearance is required for workpiece loading/unloading, set the total stroke to 100 mm to provide a safety margin.)
 - Determine the hydraulic cylinder bore size.
 (Example : For a 40 kN output at 0.5 MPa air pressure, choose a φ63 bore (43.6 kN output) by referring to the output table on page 3. This results in a pneumatic booster pressure ratio of 1 : 28.)
 - Determine the required high thrust stroke within the total stroke decided in step ①.
 - Calculate the rapid feed and high thrust feed oil capacity using the results from step ① through ③.
 Rapid feed oil capacity
 φ63(Bore area) × 10 cm(Stroke)=312 cm³
 High thrust feed oil capacity
 φ63(Bore area) × 0.3 cm(Stroke)=9.3 cm³
 - From these results, we determine the required hydraulic cylinder specifications to be 63 mm bore and 100 mm stroke.
 If there is no oil loss, refer to Table ② and select 480 cm³, which is the closest capacity exceeding the 312 cm³ rapid feed capacity. Similarly, from Table ③, select 10 cm³ for the high thrust feed capacity.
 Based on these criteria, model PB-100-1505-28 is selected.
- (Example: For punching 1.6 mm thick material, select a 3 mm high thrust stroke to ensure a safety margin, even though the theoretical stroke is only 1.6 mm.)
 ※ Set the high thrust feed oil capacity to 1.5 x or more of the net requirement for optimal safety margin.
- However, when using hydraulic hoses, add the oil loss due to hose expansion (refer to page 8) to the high thrust oil capacity. Additionally, if the cylinder or piping has a large internal volume, add the oil compression loss (refer to the next section).

Estimated Amount of Oil Compression

$$\Delta V = 10 \beta P V 1$$

Oil temperature	20°C	40°C	60°C
β	6.8×10^{-5}	7.7×10^{-5}	8.6×10^{-5}

V1 = Original volume (Inside volume of the hydraulic cylinder and piping)
 β = Compression rate
 P = Oil pressure (MPa)
 ΔV = Estimated amount of oil compression

Air Consumption

■ Symbol of fast feed oil capacity						■ Symbol of high thrust feed oil capacity							
Unit: L (ANR)						Unit: L (ANR)							
Model	Symbol	05	10	15	20	25	Model	Symbol	05	10	15	20	25
PB- 50-□-23		0.8	1.7	2.6	3.4	4.3	PB- 50-□-23		1.4	2.6	3.7	4.9	6.0
PB-100-□-16		4.6	8.0	11.4	14.8	18.1	PB-100-□-16		7.7	12.2	16.8	21.3	25.8
PB-100-□-28		4.8	8.2	11.7	15.1	18.6	PB-100-□-28		7.8	12.4	17.0	21.6	26.2
PB-160-□-16		13.7	22.2	30.8	39.4	47.9	PB-160-□-16		24.4	36.0	47.5	59.1	70.6
PB-160-□-28		14.0	22.7	31.4	40.2	48.9	PB-160-□-28		24.7	36.5	48.2	59.9	71.6
PB-200-□-25		36.9	55.4	73.8	91.7	110.0	PB-200-□-25		46.5	64.7	83.0	101.0	120.0
PB-300-□-29		85.1	126.0	168.0	209.0	250.0	PB-300-□-29		99.3	141.0	182.0	223.0	264.0

The values represent the air consumption per cycle, converted to atmospheric pressure, when the total oil volume is discharged at an air pressure of 0.5 MPa.

Example) PB-100-0510-28
 Rapid feed (05) = 4.8 L
 High thrust feed (10) = 12.4 L

Air consumption
 4.8 L + 12.4 L = 17.2 L

Dimensions

PB - 50

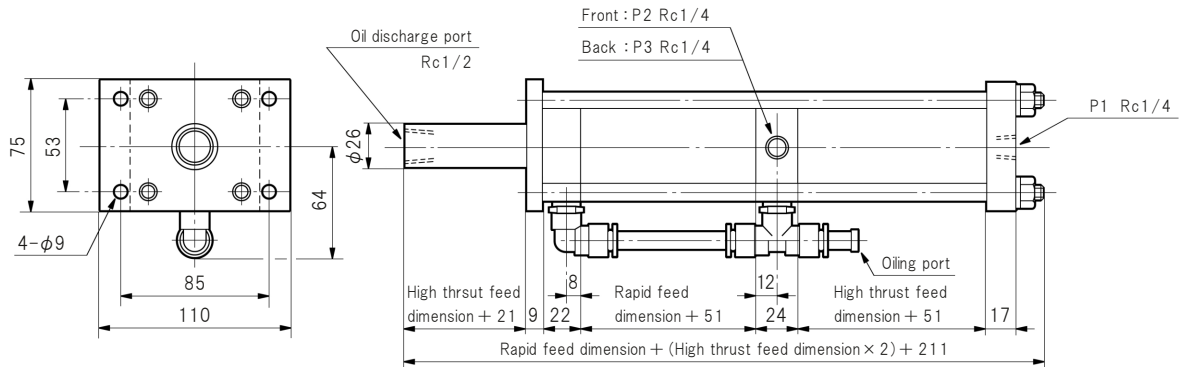

(Unit: mm)

Symbol of Rapid feed oil capacity Symbol of High thrust feed oil capacity	Rapid feed dimension High thrust feed dimension
05	50
10	100
15	150
20	200
25	250

PB - 100 PB - 160 PB - 200

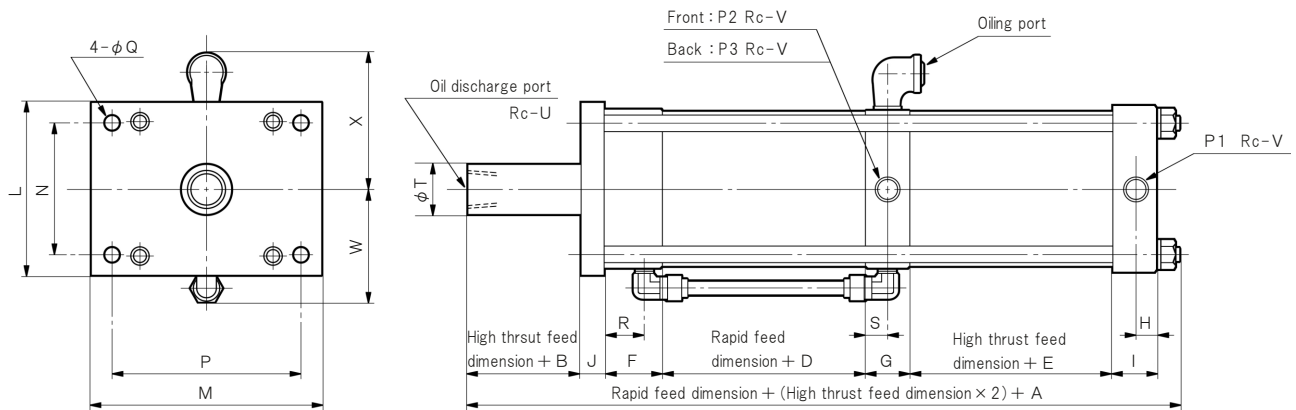

(Unit: mm)

Symbol Model	A	B	D	E	F	G	H	I	J	L	M	N	P	Q	R	S	T	U	V	W	X
PB-100	340	29	90	90	40	30	15	30	16	120	160	90	130	11	28	15	43	3/4	3/8	85	98
PB-160	459	40	120	120	59	39	24	44	15	180	220	140	190	11	39	19	50	1 1/4	1/2	118	143
PB-200	610	48	180	155	80	45	27	50	22	225	280	180	240	17	55	22	70	1 1/2	3/4	139	164

(Unit: mm)

Symbol of Rapid feed oil capacity Symbol of High thrust feed oil capacity	Rapid feed dimension High thrust feed dimension
05	50
10	100
15	150
20	200
25	250

Dimensions

PB-300

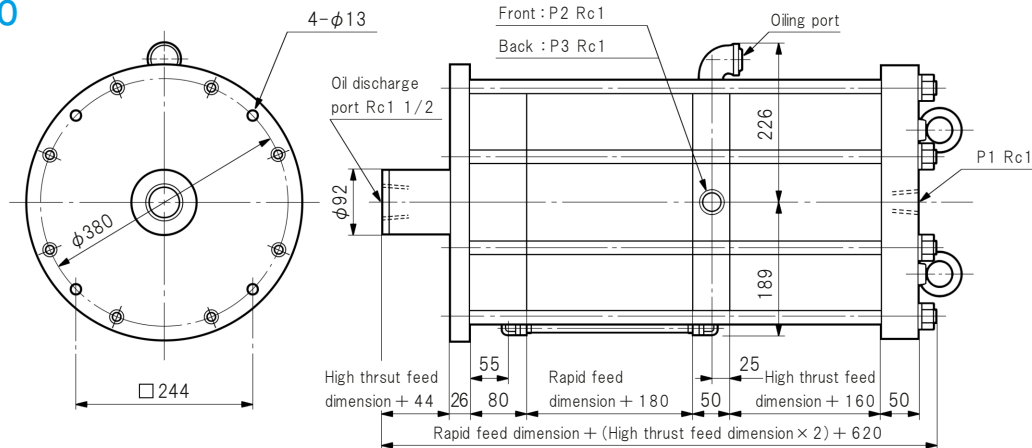

(Unit: mm)

Symbol of Rapid feed oil capacity Symbol of High thrust feed oil capacity	Rapid feed dimension High thrust feed dimension
05	50
10	100
15	150
20	200
25	250

Mass

(Unit: kg)

Model	Symbol Basic weight	Symbol of Rapid feed oil capacity					Symbol of High thrust feed oil capacity				
		05	10	15	20	25	05	10	15	20	25
PB- 50-□-23	2.2	0.21	0.42	0.63	0.84	1.05	0.32	0.64	0.96	1.28	1.60
PB-100-□-16	8.6	0.52	1.04	1.56	2.08	2.60	0.95	1.90	2.85	3.80	4.75
PB-100-□-28	8.4	0.43	0.86	1.29	1.72	2.15	0.85	1.70	2.55	3.40	4.25
PB-160-□-16	22.3	1.11	2.22	3.33	4.44	5.55	1.34	2.68	4.02	5.36	6.70
PB-160-□-28	21.4	0.90	1.80	2.70	3.60	4.50	1.33	2.66	3.99	5.32	6.65
PB-200-□-25	110.0	3.50	7.00	10.5	14.0	17.5	3.50	7.00	10.5	14.0	17.5
PB-300-□-29	250.0	9.50	19.0	28.5	38.0	47.5	9.50	19.0	28.5	38.0	47.5

Example
PB-100-1020-28
Basic weight = 8.4
Rapid feed oil capacity (10) = 0.86
High thrust feed oil capacity (20) = 3.40
Unit weight
8.4 + 0.86 + 3.40 = 12.66 kg

Handling Precautions

1 Installation

Install the Pneumatic Booster vertically with the oil discharge port facing downward. To facilitate air bleeding, please ensure the minimum oil level of the pneumatic booster is positioned higher than the hydraulic cylinder. However, if the oil volume within the hydraulic piping between the Pneumatic Booster and the hydraulic cylinder is 50% or less of the actual oil volume required for the cylinder's rapid feed stroke, installation at a lower level is permissible. (Air within the hydraulic piping is discharged inside the pneumatic booster through the reciprocating action of the hydraulic cylinder.)

2 Piping

It is recommended to exhaust the solenoid valve through a mist separator or similar equipment to prevent oil mist dispersal.

3 Hydraulic Fluid

Standard mineral hydraulic fluid
ISO viscosity grade of VG22 or VG32

Oil brand	Product name*Viscosity
Royal Dutch Shell	Tellus S2V22 or 32
Exxon Mobil	DTE 22 or 24

4 Lubrication

Remove the oiling port plug and supply oil using an oiler or similar tool.

5 Required Oil Quantity

(Unit: L)

Model	Symbol of Rapid feed oil capacity				
	05	10	15	20	25
PB- 50	0.2	0.3	0.4	0.5	0.6
PB-100	0.8	1.2	1.6	2.0	2.4
PB-160	2.4	3.4	4.4	5.4	6.3
PB-200	5.2	6.7	8.2	9.7	11.2
PB-300	12.2	15.7	19.3	22.8	26.3

※ The value indicates the oil capacity of only the Pneumatic Booster. Oil in hydraulic piping is not included. Values include a slight margin.

Related Products

Hydraulic Cylinder

Optimized for use with pneumatic boosters.
Compatible with both pneumatic and hydraulic systems.



Individual catalogs available.

Stop Valve

Use in conjunction with this unit for applications requiring emergency stops, intermediate stop, or inching.



Individual catalogs available.

Hydraulic Hose

High pressure hoses with minimal expansion are available.
(Maximum operating pressure 24 MPa)

How to order

KHP- 1/4 1000 T - L G

① ② ③ ④ ⑤

- ① Both end connection thread
- ② Hose length (mm) (Increments of 50 mm, Maximum 2000 mm)
- ③ Left side adapter } T...Straight type L...Elbow type
- ④ Right side adapter }
- ⑤ Wire braid
 - Nil Without wire braid
 - G With wire braid

Dimension

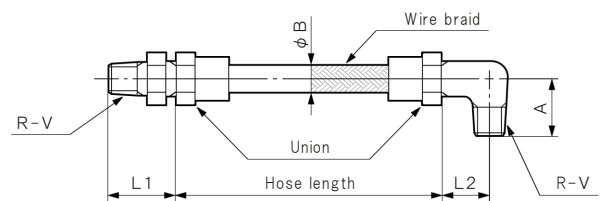

(Unit: mm)

V	1/4	3/8	1/2	3/4	1	1 1/4	1 1/2	2
A	26	30	36	43	50	58	63	75
φ B	15.0	18.5	23.0	29.5	37.0	48.4	55.3	70.5
L1	27	30	36	41	43	50	51	60
L2	15	17	20	24	27	34	36	46
Min. bending radius	70	90	110	170	220	330	400	470

Oil Loss due to Hose Expansion

(Unit: cm³)

Pressure	Model	KHP-1/4	KHP-3/8	KHP-1/2	KHP-3/4	KHP-1	KHP-1 1/4	KHP-1 1/2	KHP-2
5 MPa		0.5	0.7	0.8	0.9	1.2	1.5	1.7	2.0
10 MPa		1.0	1.3	1.4	1.8	2.3	3.0	3.3	4.0
15 MPa		1.5	2.0	2.2	2.7	3.5	4.5	5.0	6.0
20 MPa		2.0	2.5	2.8	3.6	4.6	5.9	6.6	8.0

Values represent the theoretical oil loss per meter at each pressure level.



HIROTAKA MFG. CO.,LTD.

HEAD OFFICE 5-89, Ikoma-cho, Kita-ku, Nagoya City, Aichi 462-0832, JAPAN

Phone +81-52-991-6111 Fax +81-52-991-6115

●LINE UP●

PNEUMATIC POWER CYLINDER

PNEUMATIC BOOSTER

POWER PACK CYLINDER

RUSH BOOSTER

HYDRAULIC CYLINDER

FREE LOCK PAD

SELLOCK CYLINDER

FLOATING CONNECTOR

AUTO CLAMPER

SEL NUT

LINEA BRAKE

PNEUMATIC AND HYDRAULIC

EQUIPMENT